

(54) **PROGRAMMABLE FREQUENCY DIVIDER**

(75) Inventors: **Peter R. Kinget**, Aliso Viejo, CA (US);
Nagendra Krishnapura, New York,
 NY (US)

(73) Assignee: **Lucent Technologies, Inc.**, Murray
 Hill, NJ (US)

(*) Notice: Subject to any disclaimer, the term of this
 patent is extended or adjusted under 35
 U.S.C. 154(b) by 0 days.

(21) Appl. No.: **09/511,987**

(22) Filed: **Feb. 24, 2000**

(51) **Int. Cl.**⁷ **H03K 21/00**

(52) **U.S. Cl.** **327/115; 327/117; 327/147**

(58) **Field of Search** 327/115, 117,
 327/147, 156, 231, 234, 235, 237, 238;
 377/47, 48

(56) **References Cited**

U.S. PATENT DOCUMENTS

- 5,781,054 * 7/1998 Lee 327/231
- 6,052,034 * 4/2000 Wang et al. 331/2
- 6,111,470 * 8/2000 Dufour 331/17

OTHER PUBLICATIONS

A Low Power Truly-modular 1.8GHz Programmable
 Divider in Standard CMOS Technology, Cicero Vaucher and
 Zhenhua Wang, Philips Research Labs Eindhoven, Philips
 Semiconductors Zurich, pp. 406-409.

A 5.3 GHz Programmable Divider for HiPerLAN in 0.25 μ m
 CMOS, N. Krishnapura, P. Kinget, Bell Laboratories,
 Lucent Technologies, Murray Hill, NJ 07974, USA, pp.
 142-145.

* cited by examiner

Primary Examiner—Tuan T. Lam

Assistant Examiner—Hiep Nguyen

(57) **ABSTRACT**

We have recognized that the design and programming com-
 plexity associated with conventional frequency divider con-
 figurations can be significantly reduced by a configuration of
 functionally identical, modular division blocks which are
 each able to swallow at least one input cycle of a input signal
 by switching to a phase-lagging output once per output
 cycle. The number of input pulses swallowed when a
 division block switches to a lagging waveform is a direct
 function of the division block's location in the chain, such
 that the number of input cycles swallowed per phase switch
 increases moving down the chain of division blocks.
 Therefore, the chain of division blocks has discrete elements
 for achieving most-significant to least-significant division
 factor increments. The total number of input cycles swal-
 lowed by the chain of division blocks equals the sum of
 cycles swallowed by each division block. Thus, to achieve
 a variety of division factors, a controller controls which, if
 any, division blocks switch to a phase-lagging waveform
 once each output cycle. Furthermore, we have recognized
 that the range of division factors which may be achieved by
 the chain of frequency dividers can be increased by con-
 trolling at least one division block to switch to a phase-
 leading waveform once each output cycle.

32 Claims, 5 Drawing Sheets

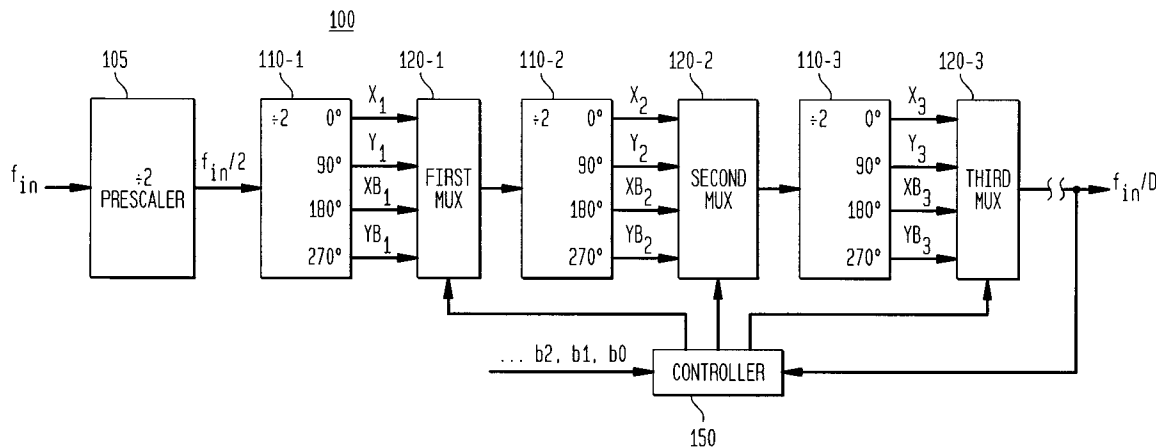

FIG. 1

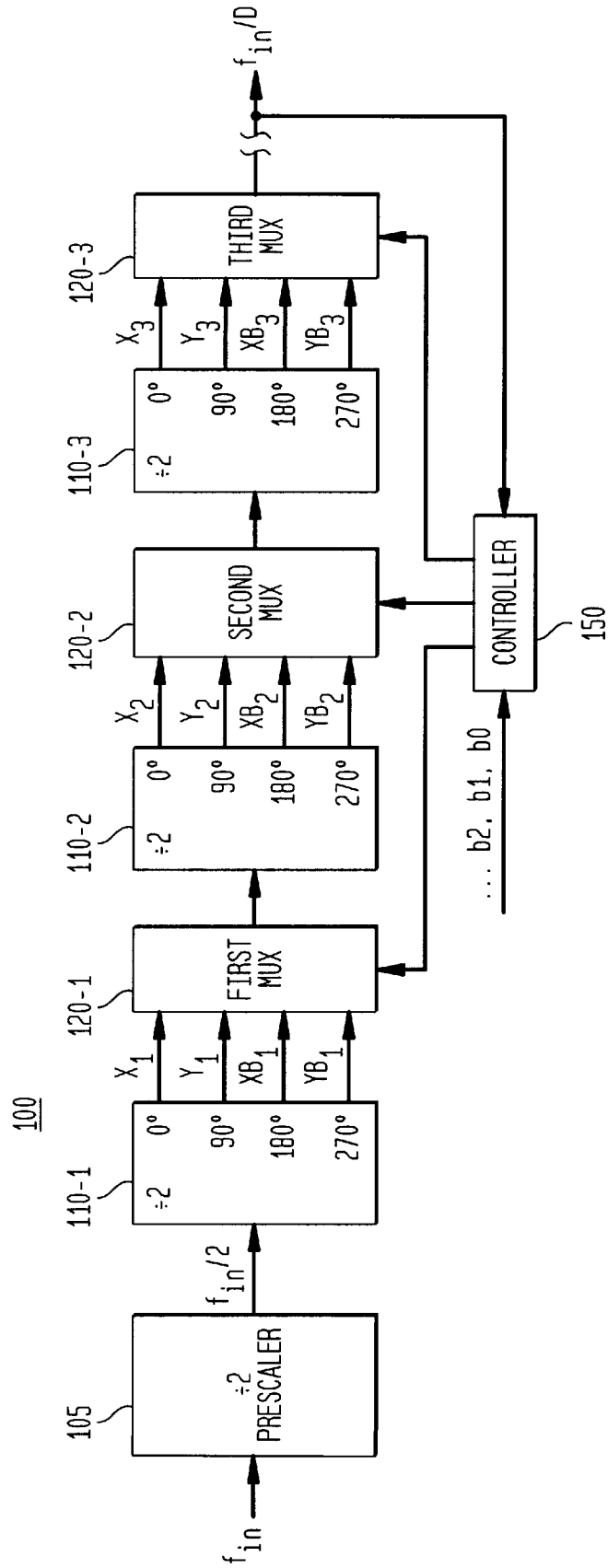

FIG. 2

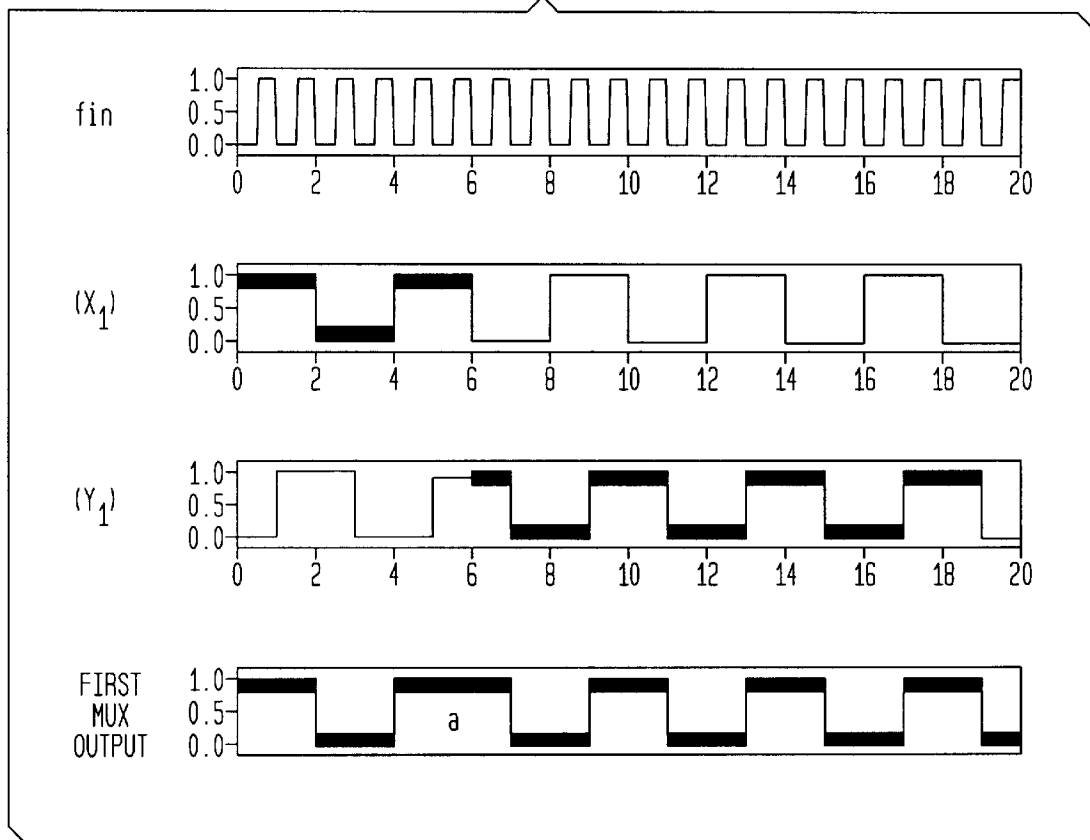

FIG. 3

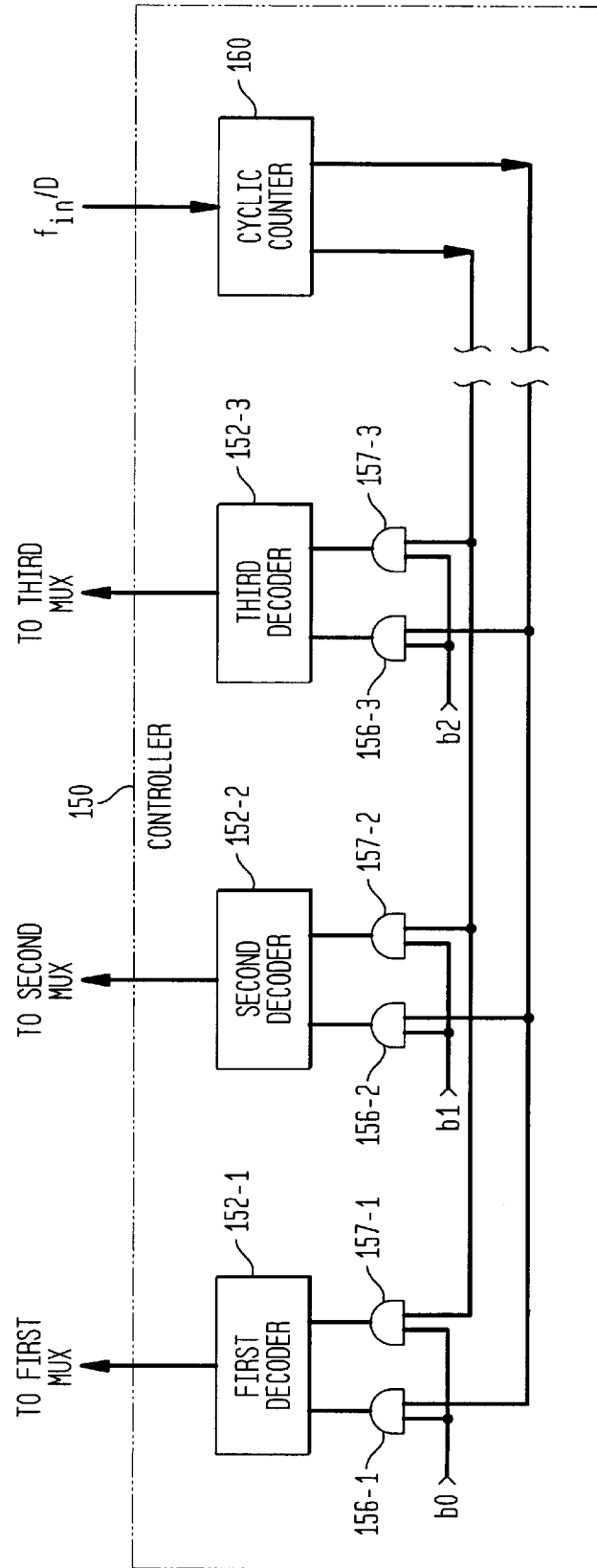

FIG. 4

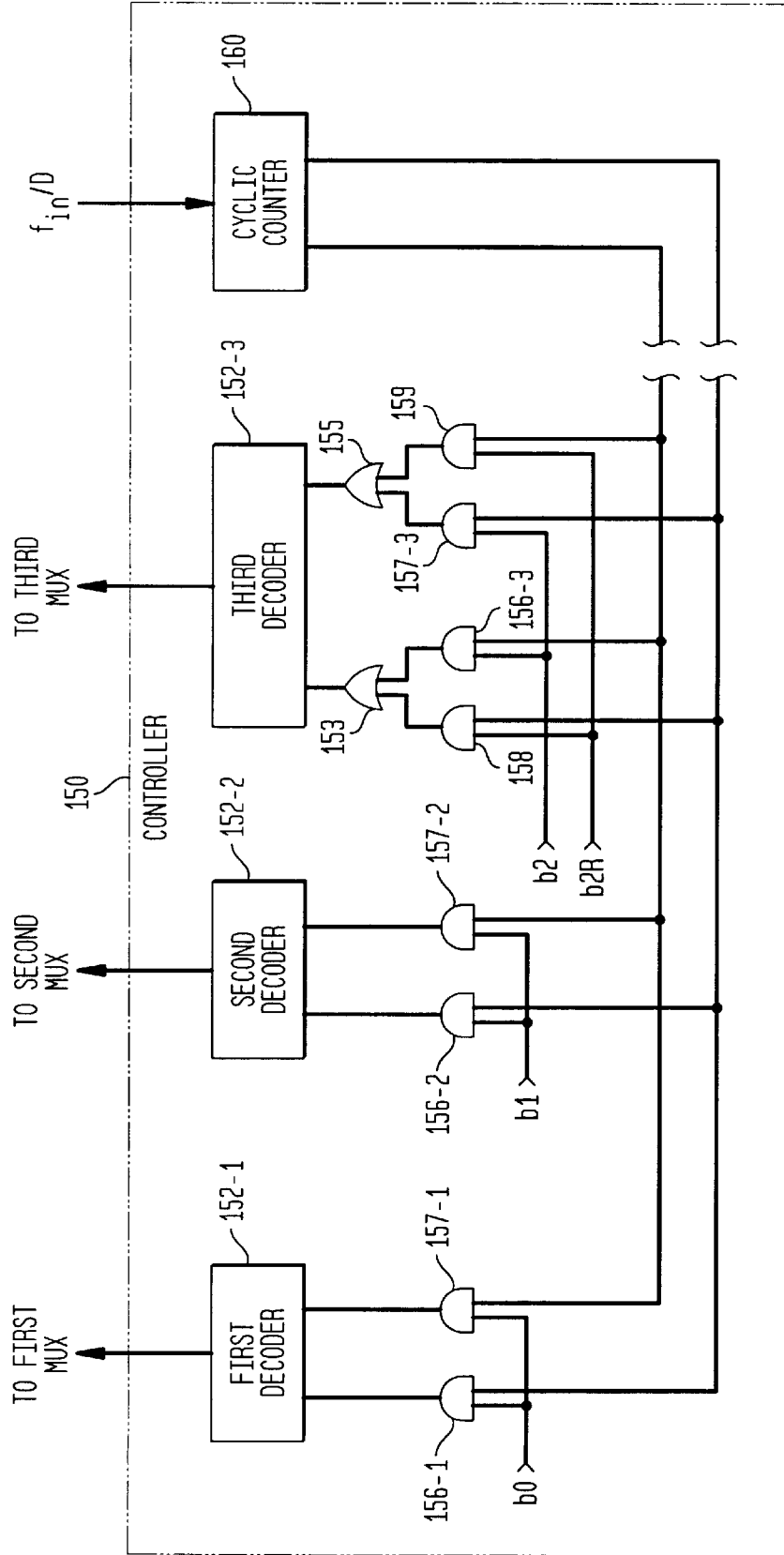
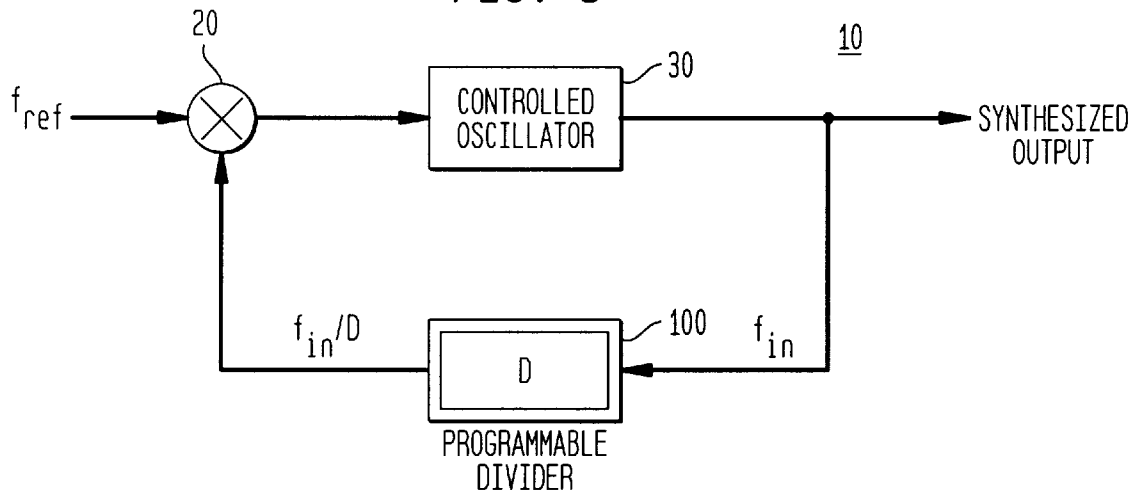

FIG. 5



PROGRAMMABLE FREQUENCY DIVIDER

TECHNICAL FIELD

This invention relates to programmable frequency dividers and frequency synthesizers.

BACKGROUND OF THE INVENTION

It is well known that programmable frequency dividers are commonly used in phase-lock-loop (PLL) frequency synthesizers, such as for generating a local oscillating signal in a receiver or a carrier signal in a transmitter. One conventional type of programmable frequency divider is a phase-switching-type frequency divider which includes a) a prescaler which divides the frequency of an input waveform, f_{in} , by two, b) a divide-by-two circuit which divides the frequency of the prescaler output by two and outputs four phase-offset versions of $f_{in}/4$ — offset by 0° , 90° , 180° , and 270° respectively, c) a multiplexer for selectively switching between the four outputs of the divide-by-two circuit, d) a divide-by-N circuit for dividing the frequency of the waveform output by the multiplexer by N, e) a pulse generator for generating K pulses per output cycle of the frequency divider, f) a four-state counter for incrementing after each pulse of the pulse generator, and g) a decoder for controlling the multiplexer based on the four-state counter output. To swallow one cycle of f_{in} and thereby increase the division factor of the frequency divider by one, the multiplexer switches to an output of the divide-by-two circuit which lags the previously selected output by 90° . If the decoder controls the multiplexer to switch to a 90° lagging output K times per output cycle of the frequency divider, i.e., each time the counter increments, K input cycles are swallowed and the division factor becomes $4N+K$. To achieve programmability, the pulse generator must be able to generate various numbers of pulses each output cycle, depending on K. Designing and programming such a pulse generator is complicated. Also, for large values of K, the pulse generator, the divide-by-four counter, and the decoder must operate at high frequencies, thereby increasing power consumption.

SUMMARY OF THE INVENTION

We have recognized that the design and programming complexity associated with conventional frequency divider configurations can be significantly reduced in accordance with the principles of the invention, in which a programmable frequency divider includes a chain of functionally identical, modular division blocks which are each able to swallow at least one input cycle by switching to a phase-lagging output once per output cycle. The number of input pulses swallowed when a division block switches to a phase-lagging waveform is a direct function of the division block's location in the chain, such that the number of input cycles swallowed per phase switch increases moving down the chain of division blocks. Therefore, the chain of division blocks has discrete elements for achieving most-significant to least-significant division factor increments, and the total number of input cycles swallowed by the chain of division blocks equals the sum of cycles swallowed by each division block. Thus, to achieve a variety of division factors, a controller controls which, if any, division blocks switch to a phase-lagging waveform once each output cycle.

In one exemplary embodiment of the invention, a frequency divider includes a divide-by-two prescaler, a chain of functionally identical, modular divide-by-two blocks following the prescaler, and a controller. Each divide-by-two block includes a divide-by-two circuit which outputs four

waveforms that are offset by 0° , 90° , 180° , and 270° respectively, and a multiplexer which selects one waveform output based on a control signal received from the controller. Control bits b_M, \dots, b_0 are set according to the desired division factor and converted by the controller to a multiplexer control signal for each divide-by-two block. Division factors varying from 2^{M+2} to $2^{M+2} + 2^{M+1} - 1$ can be achieved using a chain of M+1 division blocks by setting each control bit b_M, \dots, b_0 to either 1 or 0.

We have further recognized that switching to a phase-leading waveform will shorten a pulse of a waveform, and that the controller can control a divide-by-two block to switch to a phase-leading waveform once per output cycle to achieve certain division factors which are less than 2^{M+2} . Therefore, a frequency divider structure with M+1 divide-by-two blocks can achieve division factors that are less than 2^{M+2} , but which cannot be achieved with a frequency divider structure with less than M+1 divide-by-two stages. Setting a control bit b_{MR} to 1 or 0 instructs the controller to selectively control the multiplexer of the last divide-by-two block to switch to a phase-leading waveform each output cycle.

Advantageously, various division factors may be readily achieved according to the principles of the present invention by selecting a number of division blocks, deciding whether the last division block should switch to a phase-leading output once per output cycle, and determining which, if any, division blocks should switch to a phase-lagging output once per output cycle. In this way, the frequency divider of the present invention is scalable and easily programmable, and does not require a pulse generator to control phase switching. Furthermore, because each multiplexer switches to a different output at most once per output cycle, most elements of the frequency divider operate at relatively low frequency, thereby reducing power consumption.

BRIEF DESCRIPTION OF THE DRAWINGS

In the drawings:

FIG. 1 shows an exemplary frequency divider structure in accordance with the principles of the present invention;

FIG. 2 shows a series of waveforms illustrating the principles of phase swallowing;

FIG. 3 shows an exemplary control logic structure which controls phase shifts for the frequency divider structure of FIG. 1 in accordance with the principles of the invention;

FIG. 4 shows an exemplary control logic structure for the frequency divider of FIG. 1 which controls forward and reverse phase shifts in the last divide-by-two block to increase the number of possible division factors in accordance with the principles of the present invention; and

FIG. 5 shows an exemplary PLL frequency synthesizer which incorporates a frequency divider in accordance with the principles of the present invention.

DETAILED DESCRIPTION

FIG. 1 shows an exemplary programmable frequency divider **100** which may be scaled and directly programmed to achieve a desired division factor in accordance with the principles of the invention. Frequency divider **100** includes 1) prescaler **105**, 2) first divide-by-two circuit **110-1**, 3) second divide-by-two circuit **110-2**, 4) third divide-by-two circuit **110-3**, 5) first multiplexer **120-1**, 6) second multiplexer **120-2**, 7) third multiplexer **120-3**, and 8) controller **150**. As described in more detail below, although three divide-by-two blocks (a "block" being a combination of a divide-by-two circuit and a multiplexer) are shown in the

exemplary embodiment of FIG. 1, frequency divider **100** can be easily scaled to include additional or fewer divide-by-two blocks, depending on the desired division factor.

Prescaler **105** receives a reference frequency, f_{in} , and divides f_{in} by two. First divide-by-two circuit **110-1** receives $f_{in}/2$ from prescaler **105**, divides $f_{in}/2$ by two, and outputs four phase-offset versions of $f_{in}/4$, specifically, $f_{in}/4$ at 0° phase-offset (X_1), $f_{in}/4$ at 90° lagging (Y_1), $f_{in}/4$ at 180° lagging (XB_1), and $f_{in}/4$ at 270° lagging (YB_1). Divide-by-two circuits which output four phase-offset waveforms have been used in prior art frequency dividers and are well known. Any suitable device may be used as a divide-by-two circuit in the present invention, e.g., a master-slave flip-flop. First multiplexer **120-1** receives X_1 , Y_1 , XB_1 , and YB_1 from first divide-by-two circuit **110-1**, and outputs one of X_1 , Y_1 , XB_1 , and YB_1 in accordance with a control signal received from controller **150**.

Second divide-by-two circuit **110-2** receives the $f_{in}/4$ waveform output by first multiplexer **120-1** and divides the $f_{in}/4$ waveform by two. Second divide-by-two circuit **110-2** outputs four phase-offset versions of the resulting $f_{in}/8$ waveform, specifically, $f_{in}/8$ at 0° phase-offset (X_2), $f_{in}/8$ at 90° lagging (Y_2), $f_{in}/8$ at 180° lagging (XB_2), and $f_{in}/8$ at 270° lagging (YB_2). Second multiplexer **120-2** receives X_2 , Y_2 , XB_2 , and YB_2 from second divide-by-two circuit **110-2**, and outputs one of X_2 , Y_2 , XB_2 , and YB_2 in accordance with a control signal received from controller **150**.

Third divide-by-two circuit **110-3** receives the $f_{in}/8$ waveform from second multiplexer **120-2**, divides the $f_{in}/8$ waveform by two, and outputs four phase-offset versions of the resulting $f_{in}/16$ waveform, specifically $f_{in}/16$ at 0° phase-offset (X_3), $f_{in}/16$ at 90° lagging (Y_3), $f_{in}/16$ at 180° lagging (XB_3), and $f_{in}/16$ at 270° lagging (YB_3). Third multiplexer **120-3** receives X_3 , Y_3 , XB_3 , and YB_3 from third divide-by-two circuit **110-3**, and outputs one of X_3 , Y_3 , XB_3 , and YB_3 in accordance with a control signal received from controller **150**.

A 90° phase lag at $f_{in}/4$ is equal to one cycle at f_{in} . Thus, control logic **150** can selectively control first multiplexer **120-1** to switch from a current waveform to a 90° lagging waveform, i.e., switching from X_1 to Y_1 , Y_1 to XB_1 , XB_1 to YB_1 , or YB_1 to X_1 , to swallow one cycle of f_{in} . Controller **150** can increase the division factor of frequency divider **100** by one by controlling first multiplexer **120-1** to switch to a 90° lagging waveform once each output cycle.

FIG. 2 shows a series of waveforms which illustrate the pulse swallowing achieved when first multiplexer **120-1** switches to a 90° lagging $f_{in}/4$ waveform. FIG. 2 shows f_{in} , X_1 , Y_1 , and an exemplary output of first multiplexer **120-1** when controller **150** controls first multiplexer **120-1** to switch from X_1 to Y_1 . In each of the X_1 and Y_1 waveforms shown in FIG. 2, thick lines denote the time when that waveform is selected by first multiplexer **120-1**, such that the waveform output by first multiplexer **120-1** is a combination of portions from X_1 and Y_1 . As shown in FIG. 2, when first multiplexer **120-1** switches from X_1 to Y_1 , a pulse of the final waveform, labeled pulse "a," is extended by one cycle of f_{in} , thereby increasing the division factor of frequency divider **100** by one if repeated once per output cycle.

A 90° phase lag at $f_{in}/8$ is equal to two cycles of f_{in} . Thus, controller **150** can selectively control second multiplexer **120-2** to switch from a current waveform to a 90° lagging waveform to swallow two cycles of f_{in} . Controller **150** can control second multiplexer **120-2** to switch from a current waveform to a 90° lagging waveform once each output cycle to increase the division factor of frequency divider **100** by

two. Still further, a phase lag of 90° at $f_{in}/16$ is equal to four cycles of f_{in} . Thus, controller **150** can selectively control third multiplexer **120-3** to switch from a current waveform to a 90° lagging waveform to swallow four cycles of f_{in} . Controller **150** can control third multiplexer **120-3** to switch from a current waveform to a 90° lagging waveform once each output cycle to increase the division factor of frequency divider **100** by four.

In this manner, the number of input cycles swallowed by a switch to a 90° lagging waveform increases by a power of 2 down the chain of divide-by-two blocks, and if the controller **150** controls two or more of first, second, and third multiplexers **120-1**, **120-2**, and **120-3** to switch to a 90° lagging waveform during the same output cycle, the total number of cycles swallowed is equal to the sum of the individual number of cycles swallowed by each divide-by-two block, e.g., phase switching at first multiplexer **120-1** and third multiplexer **120-3** during the same output cycle swallows five additional input cycles. Thus, according to principles of the present invention, a frequency divider provides a range of least-significant frequency division increments to most-significant frequency division increments using a chain of functionally identical frequency dividers.

Controller **150** receives a plurality of control bits b_0 , b_1 , b_2 to control which of first, second, and third multiplexers **120-1**, **120-2**, and **120-3**, if any, switch phases each output cycle. Accordingly, the division factor, D, for the exemplary frequency divider **100** structure having three divide-by-two blocks shown in FIG. 1 can be expressed as:

$$D=2^4+b_0\cdot 2^0+b_1\cdot 2^1+b_2\cdot 2^2. \quad (1)$$

By varying b_2 , b_1 , b_0 from 0,0,0 to 1,1,1, division factors from 16 to 23 can be obtained. Although equation (1) assumes that a control bit of 1 indicates that a corresponding multiplexer should switch to a 90° lagging waveform each output cycle, those skilled in the art will realize that a control bit of 0 could alternatively be used to signify that a corresponding multiplexer should switch to a 90° lagging waveform.

Although frequency divider **100** of FIG. 1 includes a divide-by-two prescaler **105** and a chain of three divide-by-two blocks, frequency divider **100** may be easily scaled to include fewer or greater divide-by-two blocks, depending on the desired division factor. For example, if a division factor greater than 32 and less than 48 is desired, frequency divider **100** will include a chain of four divide-by-two blocks, and varying control bits b_3 , b_2 , b_1 , b_0 from 0,0,0,0 to 1,1,1,1 will achieve division factors of 32 to 47. Therefore, the division factor, D, for frequency divider **100** with M+1 divide-by-two blocks can generally be expressed as:

$$D=2^{M+2}+b_0\cdot 2^0+\dots+b_M\cdot 2^M, \quad (2)$$

and division factor from $2^{M+2}+2$ to $2^{M+2}+2^{M+1}-1$ can be achieved by varying b_M, \dots, b_0 from all 0's to all 1's (or vice versa).

FIG. 3 shows an exemplary configuration for controller **150** which controls first, second, and third multiplexers **120-1**, **120-2**, and **120-3** in accordance with control bits b_0 , b_1 , and b_2 respectively. Controller **150** includes i) first, second, and third decoders **152-1**, **152-2**, **152-3**, ii) first, second, and third high-order bit AND gates **156-1**, **156-2**, **156-3**, iii) first, second, and third low-order bit AND gates **157-1**, **157-2**, **157-3**, and iv) cyclic counter **160**. In this exemplary configuration, cyclic counter **160** is a four-state counter, e.g., for counting in a two-bit gray-code sequence of

00, 01, 11, 10, which increments at each output cycle of f_{in}/D . Cyclic counters have been used in prior art frequency dividers and are well known in the art. Any suitable counter circuit can be used for cyclic counter **160**.

First decoder **152-1** receives outputs from first high-order bit AND gate **156-1** and first low-order bit AND gate **157-1** and converts the resulting two bits to a multiplexer command, such that decoder **152-1** commands first multiplexer **120-1** to output one of X_1, Y_1, XB_1 , and YB_1 . Second decoder **152-2** receives outputs from second high-order bit AND gate **156-2** and second low-order bit AND gate **157-2** and converts the resulting two-bits to a multiplexer command, such that decoder **152-2** commands second multiplexer **120-2** to output one of X_2, Y_2, XB_2, YB_2 . Third decoder **152-3** receives outputs from third high-order bit AND gate **156-3** and third low-order bit AND gate **157-3** and converts the resulting two bits to a multiplexer command, such that third decoder **152-3** commands third multiplexer **120-3** to output one of X_3, Y_3, XB_3, YB_3 .

Decoders which convert a cyclic counter output to a multiplexer control signal have been used in prior art frequency dividers, and are well known. First, second, and third decoders **152-1, 152-2, and 152-3** may be any suitable decoder. Furthermore, first, second, and third decoders **152-1, 152-2, 152-3** may be a decoding and retiming device such as that we disclosed in N. Krishnapura & P. Kinget, *A 5.3 GHz Programmable Divider For HiPerLAN in 0.25 μm CMOS*, Proceedings of the 25th European Solid State Circuit Conference. (ESSCIRC), pp. 142–45, September, 1999, which provides “glitch free” switching, i.e., the corresponding multiplexer is controlled to switch to a lagging waveform when both the lagging waveform and the previously selected waveform are at the same level (“high” or “low”).

As an example of the operation of first, second, and third decoders **152-1, 152-2, and 152-3**, each decoder may send: an X_1 -, X_2 -, X_3 -select command to first, second, and third multiplexers, **120-1, 120-2, and 120-3** respectively, upon receiving **00**; a Y_1 -, Y_2 -, Y_3 -select command to first, second, and third multiplexers **120-1, 120-2, and 120-3** respectively, upon receiving **01**; an XB_1 -, XB_2 -, XB_3 -select command to first, second, and third multiplexers **120-1, 120-2, and 120-3** respectively, upon receiving **11**; and a YB_1 -, YB_2 -, YB_3 -select command to first, second, and third multiplexers **120-1, 120-2, and 120-3** respectively, upon receiving **10**.

First high-order bit AND gate **156-1** and first low-order bit AND gate **157-1** each receive first control bit b_0 ; second high-order bit AND gate **156-2** and second low-order bit AND gate **157-2** each receive second control bit b_1 ; and third high-order bit AND gate **156-3** and third low-order bit AND gate **157-3** each receive third control bit b_2 . When first control bit b_0 is set to 0, first decoder **152-1** receives **00** and sends an X_1 -select command to first multiplexer **120-1**; when second control bit b_1 is set to 0, second decoder **152-2** receives **00** and sends an X_2 -select command to second multiplexer **120-2**; and when third control bit b_2 is set to 0, third decoder **152-3** receives **00** and sends an X_3 -select command to third multiplexer **120-3**.

First, second, and third high-order bit AND gates **156-1, 156-2, 156-3** each also receive the first bit output from cyclic counter **160**, and first, second, and third low-order bit AND gates **157-1, 157-2, 157-3** each receive the second bit output from cyclic counter **160**. As a result, when cyclic counter **160** outputs **00**, first, second, and third decoders **152-1, 152-2, and 152-3** receive **00** (X-select) regardless of control bits b_0, b_1, b_2 . When cyclic counter **160** outputs **01**, first, second, and third decoders **152-1, 152-2, and 152-3** receive **01** (Y-select command) when the corresponding control bit

b_0, b_1, b_2 is also 1; when cyclic counter **160** outputs **11**, first, second, and third decoders **152-1, 152-2, and 152-3** receive **11** (XB-select command) when the corresponding control bit b_0, b_1, b_2 is also 1; and when cyclic counter **160** outputs **10**, first, second, and third decoders **152-1, 152-2, and 152-3** receive **10** (YB-select command) when the corresponding control bit b_0, b_1, b_2 is also 1. Accordingly, first multiplexer **120-1** switches to a 90° lagging waveform each cycle of f_{in}/D , i.e., each time cyclic counter **160** increments, when control bit b_0 is 1. Likewise, second multiplexer **120-2** switches to a 90° lagging waveform each cycle of f_{in}/D when control bit b_1 is 1, and third multiplexer **120-3** switches to a 90° lagging waveform each cycle of f_{in}/D when control bit b_2 is 1. In accordance with the control logic configuration shown in FIG. 3, only control bits b_0, b_1, b_2 need to be changed when a new division factor within a certain range is selected, and the logic circuitry can be easily scaled to include additional or fewer divide-by-two blocks and control bits to provide a higher or low range of possible division factors.

As is evident from the above discussion, certain division factors are not achieved using the configuration of controller **150** shown in FIG. 3. For example, the maximum division factor achieved by a divide-by-two prescaler and a chain of two divide-by-two blocks is 11, i.e., $D=23^3+b_1 \cdot 2^0 + b_1 \cdot 2^1$, but the minimum division factor for a configuration with a divide-by-two prescaler and a chain of three divide-by-two blocks with pulse swallowing capability is 16.

We have recognized that such gaps can be filled by selectively controlling the last divide-by-two block to switch to a 90° phase-leading waveform, instead of a 90° phase-lagging waveform, once per output cycle. In this way, the last multiplexer shortens instead of elongates the output cycle to make division factors smaller than 2^{M+2} possible.

FIG. 4 shows an exemplary configuration of controller **150** for selectively controlling the last multiplexer of frequency divider **100** to switch to a 90° phase-leading waveform once per output cycle when a division factor of 11 to 15 is desired. In addition to the elements described above with reference to FIG. 3, controller **150** shown in FIG. 4 includes high-order bit OR gate **153**, low-order bit OR gate **155**, high-order reverse count AND gate **158**, and low-order reverse count AND gate **159**. High-order reverse count AND gate **158** and low-order reverse count AND gate **159** each receive control bit b_{2R} , which is set to 1 when third multiplexer **120-3** should switch to a 90° phase-leading waveform once per output cycle, i.e., for division factors of 12 to 15. Low-order reverse count AND gate **159** also receives the high-order bit from cyclic counter **160**, and high-order reverse count AND gate **158** also receives the low-order bit from cyclic counter **160**.

High-order bit OR gate **153** receives the outputs of third high-order bit AND gate **156-3** and high-order reverse count AND gate **158**, and has an output connected to third decoder **152-3**. Low-order bit OR gate **155** receives the outputs of third low-order bit AND gate **157-3** and low-order reverse count AND gate **159**, and has an output connected to third decoder **152-3**. Therefore, third decoder **152-3** receives a two-bit control code from high-order bit OR gate **153** and low-order bit OR gate **155** for the configuration of controller **150** shown in FIG. 4. With this logic configuration, third decoder **152-3** will control third multiplexer **120-3** to switch to a 90° phase-leading waveform, i.e., X_3 to YB_3, YB_3 to XB_3, XB_3 to Y_3 , or Y_3 to X_3 , when control bit b_{2R} is 1 each time cyclic counter **160** increments, thereby resulting in a division factor of 12 to 15, depending on control bits b_1, b_0 . Control bit sequence $b_{2R}, b_1, b_0=1,1,1$ provides a division

factor of 15, $b_{2R}, b_1, b_0=1,1,0$ provides a division factor of 14, $b_{2R}, b_1, b_0=1,0,1$ provides a division factor of 13, and $b_{2R}, b_1, b_0=1,0,0$ provides a division factor of 12. When control bit b_{2R} is 0, the configuration of control logic **150** shown in FIG. 4 operates like that shown in FIG. 3 to achieve division factors of 16 to 23 based on control bits b_2, b_1, b_0 . In accordance with the principles of the present invention described above with reference to FIG. 4, division factors in the range of $2^{M+1}+2^M$ to $2^{M+2}-1$ can be achieved by controlling the last divide-by-two block to switch to a 90° phase-leading waveform each output cycle by setting control bit b_{MR} to 1 and varying control bits b_{M-1}, \dots, b_0 from 0, . . . , 0 to 1, . . . , 1. If b_{MR} is set to 1, b_M should not also be set to 1.

FIG. 5 shows an exemplary PLL frequency synthesizer **10** which includes a programmable frequency divider according to the principles of the present invention. PLL frequency synthesizer **10** includes I) phase detector **20**, II) controlled oscillator **30**, and III) a programmable frequency divider **100** according to the principles of the present invention. As described above, programmable frequency divider **100** divides an input frequency, f_{in} , by a division factor, D. Phase detector **20** receives the output of programmable frequency divider **100** and a reference frequency, f_{ref} , detects phase differences between f_{ref} and f_{in}/D , and outputs an error signal. Controlled oscillator **30**, e.g., a voltage controlled oscillator (VCO), receives the error signal output by phase detector **20**, such that the frequency of the signal output by controlled oscillator **30** is corrected based on the error signal output of phase detector **20**.

The foregoing merely illustrates the principles of the invention. It will be appreciated that those skilled in the art will be able to devise various arrangements which, although not explicitly described or shown herein, embody the principles of the invention and are thus within the spirit and scope.

We claim:

1. A programmable frequency divider comprising:

a chain of frequency divider blocks, each frequency divider block having

a frequency divider which scales a frequency of an input waveform to generate a scaled frequency waveform, and outputs multiple phase-offset versions of said scaled frequency waveform, and

a multiplexer for selecting one of said multiple phase-offset versions of said scaled frequency waveform; and

wherein said multiplexer of each frequency divider block selects a current phase-offset version of said scaled frequency waveform or a different phase-offset version of said scaled frequency waveform based on a selected division factor.

2. The invention as defined in claim 1, further comprising: a pre-scaler for receiving a reference frequency waveform, dividing said reference frequency waveform by a pre-scaling factor, and outputting a pre-scaled waveform to a first frequency divider block of said chain of frequency divider blocks.

3. The invention as defined in claim 2, wherein said programmable frequency divider has a base division factor of 2^{M+2} , said programmable frequency divider achieving said base division factor when said multiplexer of each frequency divider block selects said current phase-offset version of said scaled frequency waveform, M+1 being the number of frequency divider blocks in said chain of frequency divider blocks.

4. The invention as defined by claim 1, wherein said multiplexer selects a phase-lagging version of said scaled frequency waveform to increase a division factor achieved by said programmable frequency divider by an incremental division factor.

5. The invention as defined by claim 4, wherein each frequency divider block in said chain of frequency divider blocks has an associated weighted incremental division factor, such that the incremental division factor associated with a given frequency divider block increases moving down said chain of frequency divider blocks.

6. The invention as defined by claim 5, wherein

said programmable frequency divider further comprises a divide-by-two pre-scaler, and

said division factor, D, of said programmable frequency divider can be represented as:

$$D=2^{M+2}+b_0 2^0 + \dots + b_M 2^M,$$

where said chain of frequency divider blocks includes M+1 frequency divider blocks, and b_0, \dots, b_M are control bits which respectively indicate whether a first, . . . , M+1th frequency divider block should achieve its associated incremental division factor.

7. The invention as defined in claim 6, wherein said multiplexer of one frequency divider block of said chain of frequency divider blocks selects a phase-leading version of said reduced frequency waveform to achieve a division factor less than 2^{M+2} .

8. The invention as defined in claim 4, wherein

said frequency divider of each frequency divider block outputs a 0° phase-offset version of said scaled frequency waveform, a 90° phase-offset version of said scaled frequency waveform, a 180° phase-offset version of said scaled frequency waveform, and a 270° phase-offset version of said scaled frequency waveform, and

said multiplexer sequentially switches from said 0° phase-offset version to said 90° phase-offset version, from said 90° phase-offset version to said 180° phase-offset version, from said 180° phase-offset version to said 270° phase-offset version, and from said 270° phase-offset version to said 0° phase-offset version to achieve the incremental division factor associated with the corresponding frequency divider block.

9. The invention as defined in claim 1, wherein said programmable frequency divider further comprises a controller for designating selections made by said multiplexer of each frequency divider block.

10. The invention as defined in claim 9, wherein said controller includes a cyclic counter for receiving an output from a last frequency divider block in said chain of frequency divider blocks, incrementing a count value each cycle of said output from said last frequency divider block, and outputting said count value to said controller.

11. The invention as defined in claim 9, wherein said controller receives a single control bit for each frequency divider block in said chain of frequency divider blocks, said control bit indicating whether said multiplexer selects a current phase-offset version of said scaled frequency waveform or a different phase-offset version of said scaled frequency waveform.

12. The invention as defined in claim 9, wherein said controller includes a plurality of decoders, one for each

frequency divider block in said chain of frequency divider blocks, each decoder converting a two bit command signal into a multiplexer command signal.

13. The invention as defined in claim 10, wherein, when said controller controls said multiplexer to select a different phase-offset version of said scaled frequency waveform, said controller controls said multiplexer to select a different phase-offset version of said scaled frequency waveform once per cycle of said output from said last frequency divider block based on said count value output by said cyclic counter.

14. The invention as defined in claim 1, wherein, when said multiplexer selects a different phase-offset version of said scaled frequency waveform, said multiplexer selects a different phase-offset version of said scaled frequency waveform once per cycle of an output from a last frequency divider block in said chain of frequency divider blocks.

15. The invention as defined in claim 1, wherein said frequency divider of each frequency divider block is a divide-by-two circuit.

16. The invention as defined in claim 1, wherein the multiplexer of one frequency divider block of said chain of frequency divider blocks selects a phase-leading version of said scaled frequency waveform.

17. A phase-lock loop frequency synthesizer comprising:

- a programmable frequency divider which includes
 - a chain of frequency divider blocks for generating an output waveform, each frequency divider block having
 - a frequency divider which scales a frequency of an input waveform to generate a scaled frequency waveform, and outputs multiple phase-offset versions of said scaled frequency waveform, and
 - a multiplexer for selecting one of said multiple phase-offset versions of said scaled frequency waveform, and

wherein said multiplexer of each frequency divider block selects a current phase-offset version of said scaled frequency waveform or a different phase-offset version of said scaled frequency waveform based on a selected division factor;

a phase detector for detecting a phase difference between an output of said programmable frequency divider and a reference signal; and

an oscillator for generating an oscillating signal based on an output of said phase detector.

18. The invention as defined in claim 17, wherein said programmable frequency divider further includes a pre-scaler for receiving a reference frequency waveform, dividing said reference frequency waveform by a pre-scaling factor, and outputting a pre-scaled waveform to a first frequency divider block of said chain of frequency divider blocks.

19. The invention as defined in claim 18, wherein said programmable frequency divider has a base division factor of 2^{M+2} , said programmable frequency divider achieving said base division factor when said multiplexer of each frequency divider block selects said current phase-offset version of said scaled frequency waveform, $M+1$ being the number of frequency divider blocks in said chain of frequency divider blocks.

20. The invention as defined in claim 17, wherein said programmable frequency divider further includes a controller for designating selections.

21. The invention as defined in claim 20, wherein said controller includes a cyclic counter for receiving an output from a last frequency divider block in said chain of frequency divider blocks, incrementing a count value each cycle of said output from said last frequency divider block in said chain of frequency divider blocks, and outputting said count value to said controller.

22. The invention as defined in claim 21, wherein, when said controller controls said multiplexer to select a different phase-offset version of said scaled frequency waveform, said controller controls said multiplexer to select a different phase-offset version of said scaled frequency waveform once per cycle of said output from said last frequency divider block based on said count value output by said cyclic counter.

23. The invention as defined in claim 17, wherein, when said multiplexer selects a different phase-offset version of said scaled frequency waveform, said multiplexer selects a different phase-offset version of said scaled frequency waveform once per cycle of an output from a last frequency divider block in said chain of frequency divider blocks.

24. The invention as defined in claim 20, wherein said controller receives a single control bit for each frequency divider block in said chain of frequency divider blocks, said control bit indicating whether said multiplexer selects a current phase-offset version of said scaled frequency waveform or a different phase-offset version of said scaled frequency waveform.

25. The invention as defined in claim 20, wherein said controller includes a plurality of decoders, one for each frequency divider block in said chain of frequency divider blocks, each decoder converting a two-bit command signal into a multiplexer command signal.

26. The invention as defined in claim 17, wherein said frequency divider of each frequency divider block is a divide-by-two circuit.

27. The invention as defined by claim 17, wherein said multiplexer selects a phase-lagging version of said scaled frequency waveform to increase a division factor achieved by said programmable frequency divider by an incremental division factor.

28. The invention as defined by claim 27, wherein each frequency divider block in said chain of frequency divider blocks has an associated weighted incremental division factor, such that the incremental division factor associated with a given frequency divider block increases moving down said chain of frequency divider blocks.

29. The invention as defined by claim 28, wherein said programmable frequency divider further includes a divide-by-two pre-scaler, and said division factor, D , of said programmable frequency divider can be represented as:

$$D=2^{M+2}+b_0 \cdot 2^0 + \dots + b_M \cdot 2^M,$$

where said chain of frequency divider blocks includes $M+1$ frequency divider blocks, and b_0, \dots, b_M are control bits which respectively indicate whether a first, \dots , $M+1^{\text{th}}$ frequency divider block should achieve its associated incremental division factor.

30. The invention as defined in claim 29, wherein said multiplexer of one frequency divider block of said chain of frequency divider blocks selects a phase-leading version of

11

said reduced frequency waveform to achieve a division factor less than 2^{M+2} .

31. The invention as defined in claim **27**, wherein

said frequency divider of each frequency divider block outputs a 0° phase-offset version of said scaled frequency waveform, a 90° phase-offset version of said scaled frequency waveform, a 180° phase-offset version of said scaled frequency waveform, and a 270° phase-offset version of said scaled frequency waveform, and

said multiplexer sequentially switches from said 0° phase-offset version to said 90° phase-offset version, from

12

said 90° phase-offset version to said 180° phase-offset version, from said 180° phase-offset version to said 270° phase-offset version, and from said 270° phase-offset version to said 0° phase-offset version to achieve the incremental division factor associated with the corresponding frequency divider block.

32. The invention as defined in claim **17**, wherein the multiplexer of one frequency divider block of said chain of frequency divider blocks selects a phase-leading version of said scaled frequency waveform.

* * * * *