

A 13.56 MHz High Power and High Efficiency RF Source

Anita Gupta, Yogesh Arondekar, S. V. G. Ravindranath, H. Krishnaswamy* and B. N. Jagatap

Atomic and Molecular Physics Division, Bhabha Atomic Research Centre, Mumbai-400085, India
anitag@barc.gov.in, arondekar24@gmail.com, svgr@barc.gov.in and bnj@barc.gov.in

*Columbia University, New York, United States
hk2532@columbia.edu.

Abstract—This paper describes design and implementation of highly efficient, low cost 13.56 MHz, 1.5 kW RF source for ICP-AES. The design is based on current mode class-D power amplifier built using push-pull hybrid DRF1300. Prototype power amplifier achieves drain efficiency of 90 % for power output above 1 kW. Design shows that CMCD can achieve better efficiency compared to VMCD.

Index Terms—Class-D, high efficiency, power amplifiers.

I. INTRODUCTION

INDUCTIVELY coupled plasma for atomic emission spectroscopy (ICP-AES) systems require RF source with few kilo-watts of power and are operated at ISM frequencies (13.56/27.12/40.68 MHz). Traditionally such systems use vacuum tube based power amplifiers. These systems often have low power efficiency only 60-65 % [1]. Low efficiency leads not only to large energy loss, but also issues related to heat management. With availability of high frequency power MOSFETs it is now possible to build high efficiency solid state RF source for ICP-AES. The main attraction of solid state amplifiers is their smaller size and weight, high DC voltage, longer life, better stability and more convenient power control circuits. In addition, a solid state power amplifier would cost much less compared to its vacuum tube based counterpart.

Common technique to achieve high power at high frequency in solid state amplifiers is through combination of two or more linear power amplifiers. Power efficiency of such systems is comparable to vacuum tube based systems, but their smaller size poses even bigger challenges in heat management. In addition these circuits are quite cumbersome to implement as they require perfect phase matching between amplifiers, their drives and power combiners. Such systems cost much less than vacuum tube based systems but their cost is still high due to increased component count.

Problem of power dissipation and heat management can be resolved by using switching amplifiers as ideally they can achieve 100 % efficiency. However like linear amplifiers they have been limited to low frequency and power product. This fundamental limit exists due to device parasitics which scales with current and voltage capacity of devices. Recently many devices with improved technology have been introduced which have increased limit of frequency power product. One such device meant for switching amplifiers upto 1.7 kW power in HF range is push pull hybrid DRF1300; It contains two high power gate drivers and two power MOSFETs in a single package.

In this paper we describe development of 1.5 kW 13.56 MHz RF source for ICP-AES. It is based on high efficiency switched mode power amplifier using DRF1300. In amplifier design we have employed current mode class-D (CMCD) configuration to achieve good efficiency. This design demonstrates use of high power high frequency MOSFETs hybrids for simple, high efficiency and cost effective implementation of RF generators operating at fixed frequency.

II. DESIGN CONSIDERATION

There are many classes of switching amplifiers from class D-F and class S [2]. Amongst them most popular and simplest switching scheme is class-E [3]. Class-E operation achieves high efficiency by meeting both zero voltage switching (ZVS) and zero current switching (ZCS) conditions by proper design of load network. However, frequency of operation is limited by large drain to source capacitance and it produces higher voltage stress on switching devices compared to other switching configurations.

Traditional Class-D configuration (half and full bridge inverters) is limited by switching losses in device parasitics such as drain-source capacitance and lead inductance [4]. Problems with inverter configuration have been addressed in references [5], [6].

Class-D amplifiers have also been implemented with push-pull technique. Depending on voltage/current waveforms in switching devices, transformer coupled class-D amplifiers are divided in two categories known as voltage mode class-D (VMCD) and current mode class-D (CMCD). At low frequencies high efficiency can be achieved with both class-D amplifier configurations. However as frequency increases, loss due to charging and discharging of output capacitance of switches becomes more pronounced. Thus because of its ZVS condition CMCD achieves better efficiency compared to VMCD, at high frequency.

Major challenge in transformer coupled class-D amplifiers is design of output transformer. These schemes require wide-band transformer which may not be practical to implement in high power and high frequency applications. This problem is resolved by another CMCD architecture introduced by Kobayashi et al [7] where tank circuit is placed before transformer. Thus a transformer with passband at fundamental frequency is sufficient. Another advantage of CMCD at high power is that it splits DC power feed in two channels hence reduces current loading on PCB traces.

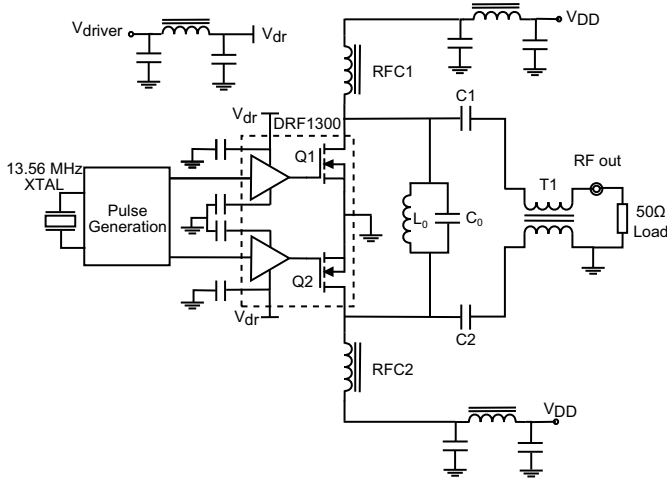

Fig. 1. Schematic diagram of 13.56 MHz RF source

In view of advantages of CMCD configuration over other switching amplifiers, it has been used to design the required 13.56 MHz, 1.5 kW RF source, as shown in Fig. 2. Power output from a CMCD amplifier in ideal case is given as

$$P_{out} = \frac{\pi^2 V_{DD}^2}{2 R_L} \quad (1)$$

and peak current through MOSFETs is $I_{peak} = \frac{\pi^2 V_{DD}}{2 R_L}$ and peak voltage is $V_{peak} = \pi V_{DD}$. Current through transistors is constant during on period, and voltage across transistors is a half sine wave during off time. As overlap of voltage and current waveform is zero, it can ideally attain 100% efficiency. However, 100% efficiency cannot be achieved due to various loss mechanisms, like finite switching time and on resistance of transistors, odd harmonic leakage currents and parasitic resistance of LC tank and output network [8].

III. IMPLEMENTATION

An RF generator with CMCD amplifier configuration has been implemented with MOSFET push-pull hybrid DRF1300.

A. Input pulse generation

In ideal case MOSFETs are driven on and off 180° out-of-phase with duty cycle of 50% in CMCD amplifier. However due to finite turn-on and turn-off time of switches they typically require duty cycle less than 50%. This leads to reduction in power efficiency of CMCD amplifier, as power loss increases with overlap between simultaneously on or partially on switches. In addition simultaneous turn-off of devices leads to potentially damaging voltage spikes due to current switching. Hence, careful adjustment of duty cycle is necessary to achieve highest possible efficiency without damaging transistors.

B. Output Network

Output network of high efficiency and high power amplifier is very critical. It consists of harmonic filters and matching

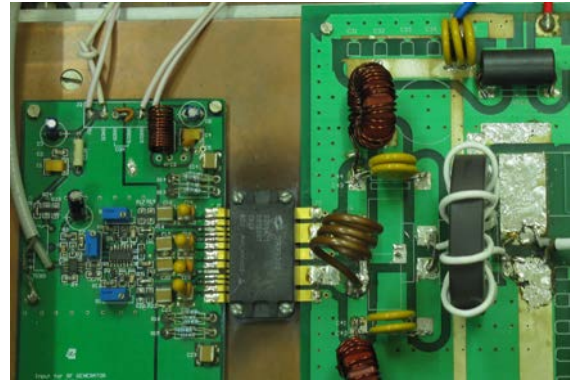

Fig. 2. Setup of 13.56 MHz RF source

network. In CMCD configuration harmonics are filtered by resonant tank circuit connected between drain terminals of two MOSFETs. Nominal value of loaded quality factor of resonant filter is 3, which is basically trade-off between harmonic control and amplifier bandwidth. Selection of tank circuit components, i.e. inductors and capacitors, is constrained by power dissipation, voltage and current ratings and their availability. As tank capacitance is a parallel combination of external capacitor, C_o , and intrinsic device capacitance, C_{oss} , its minimum value is limited to C_{oss} .

Power loss in tank circuit is governed by its unloaded quality factor. Major contribution to loss in tank circuit comes from series ESR (equivalent series resistance) of inductor and capacitors. To minimize inductor losses, it is built using copper tube with O.D. of 3 mm. Required inductance is obtained by 3 turn coil with I.D. 20 mm with resultant ESR of 0.02 ohms. Loss in capacitors is brought down by use of high quality surface mount multilayer porcelain capacitor with ESR less than 0.1 ohms. It has been further reduced by using multiple capacitors in parallel.

Balanced output across tank circuit is fed to load through a simple balun structure. A transmission line transformer 1:1 balun has been employed. In such high power amplifiers minimum inductance of transformer is not limited by $4R_L$ but by power dissipation capacity of cores, P_{max} . Minimum impedance of core can be calculated as [9]

$$X_{L,min} = \frac{V_{rms}^2}{P_{max} \left(\frac{Q}{6} + \frac{1}{Q} \right)} \quad (2)$$

where Q is quality factor of ferrite core at operating frequency and V_{rms} is rms voltage across load at maximum operation power. Transformer is constructed using material 61 with $Q \approx 60$ at 13.56 MHz and permeability of 125. Balun has been built by winding coaxial cable RG-196 over toroidal core of size OD 61 mm, ID 35.5 mm and height 12.7 mm. Required inductance 13.8 nH (based on maximum power dissipation) can be obtained by winding 9 turns. This transformer results in less than 30° rise in core temperature at maximum power.

Functioning of CMCD configuration requires constant current source instead of voltage sources as in voltage mode

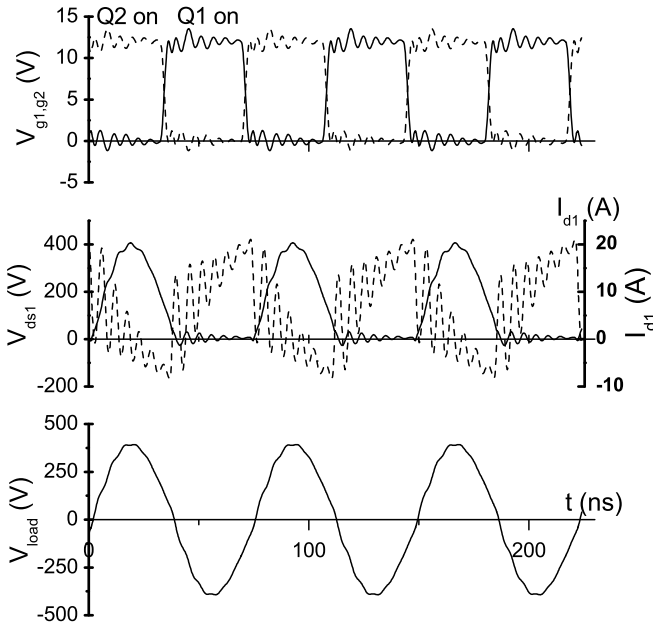

Fig. 3. Simulated current and voltage waveforms

amplifiers. Thus the important task of DC feed is to maintain constant current and isolate DC supply from RF. DC current is maintained to a constant value by means of RF choke of impedance $1\text{ k}\Omega$ at 13.56 MHz . RF choke consists of 30 turns of enameled copper wire on iron powder core T106-2 from micrometal resulting in effective inductance of $12\text{ }\mu\text{H}$. A pi-filter is used on DC supply line to keep RF out of power-supply.

C. Heat-sink

Power loss in amplifier is predominantly due to switching losses, which is dissipated as heat in the power devices. Hence to keep junction temperature within reasonable limits, very efficient heat-sink and cooling system are must. Thus devices are mounted on 10 mm thick copper heat spreader which covers $215 \times 300\text{ mm}$ surface of extrusion type aluminum heat sink. Thermal resistance of the heat sink is 0.024 K/W with forced air cooling. This arrangement is sufficient to maintain junction temperature below 100°C in worst case of operation.

IV. SIMULATIONS AND EXPERIMENTAL RESULTS

Simulation have been performed using spice model [10] with LTspice simulator [11]. Inductors and capacitors of tank circuit are modeled as ideal devices with their effective series resistance. Fig. 3 shows simulated current and voltage waveforms for supply voltage $V_{DD}=130\text{ V}$ with 1530 W output power. Voltage across MOSFETs, $V_{ds1,d2}$, is half sinusoidal (solid line). Waveform I_{d1} (dashed line) shows current through drain terminal of MOSFET, Q1. It is sum of current through the switch and fraction of tank circuit current flowing through drain capacitance, C_{oss} .

A prototype RF generator built using CMCD configuration is shown in Fig. 2. Input pulse generation circuit is adjusted

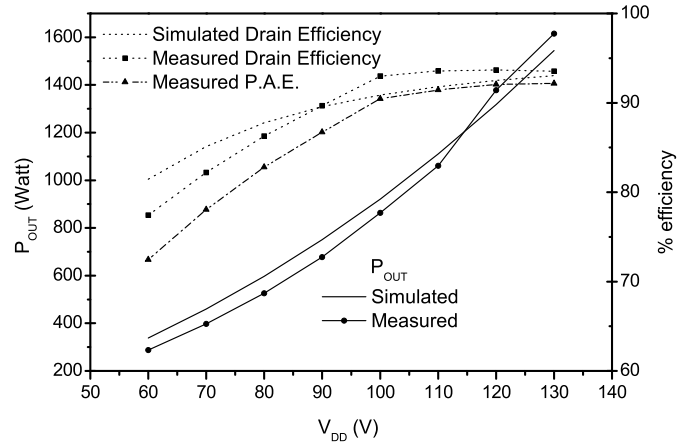

Fig. 4. Variation of output power, drain efficiency and PAE with V_{DD}

for maximum efficiency. Drive circuit is powered with 12 V power supply. Tank circuit capacitance is adjusted by taking in to account the variation of device capacitance with voltage. Generator is tested on a high power $50\text{ }\Omega$ RF load. Output power is measured by Birds RF power meter with 4024 power sensor.

Experimental results are in agreement with simulation. Fig. 4 shows variation of output power, drain efficiency and power added efficiency (PAE) with drain voltage V_{DD} for external tank circuit capacitance, $C_o = 750\text{ pF}$ and inductor L_o of 140 nH . Experimental results verify that drain efficiency as high as 94% can be achieved for output power of 1.5 kW .

V. CONCLUSION

We have demonstrated the design of high power (1.5 kW) HF source using current-mode class-D power amplifiers. Experimental results show that high efficiency (more than 90%) can be achieved with hybrid devices where drivers and MOSFETs are combined on a single package. Results show that for high frequencies CMCD can achieve better efficiency than VMCD configuration. Maximum efficiency achieved in VMCD configuration is 85% as reported by Gui Choi [12]. Increased efficiency in CMCD is achieved due to zero voltage switching. As for typical values device parasitics, losses in parasitic inductance due to current switching are much lower than losses in parasitic capacitance during voltage switching. Presented scheme is cost effective and can be implemented with ease.

Design can be easily extended to higher frequencies (upto 30 MHz) by changing values of tank circuit inductor and capacitor. To minimize the losses in tank circuit proper choice of ferrite material for balun is imperative. At lower frequencies high permeability ferrite like material 61 ($\mu_i = 125$) is required to obtain minimum required inductance. However it becomes lossy with increasing frequency (beyond 20 MHz). Hence other low loss ferrite like material 67 ($\mu_i = 40$) which is suitable for high Q applications up to 50 MHz [13], may be used for construction of balun.

ACKNOWLEDGMENT

We are grateful to Mr. Gopal Joshi and Mrs. C. I. Sujo, Electronics Division, BARC, for useful discussions at various stages of this work. We would like to thank workshop personnel for helping us in fabrication of the instrument and coils. We are thankful to Mr. R Sampathkumar for his valuable comments on manuscript. We are thankful to Dr. S. K. Mishra for helping us with LCR meter.

REFERENCES

- [1] L. Husheng and S. Xiang, *Inductively coupled plasma mass spectroscopy technology and applications*. Chemical Industry Press, 2005.
- [2] A. Grebennikov and N. O. Sokal, *Switchmode RF Power Amplifiers*. Elsevier Inc., 2007.
- [3] N. Sokal and A. Sokal, "Class E- A new class of high-efficiency tuned single ended switching power amplifiers," *IEEE J. Solid-State Circuits*, vol. SC-10, pp. 168–176, Jun. 1975.
- [4] S.-A. El-Hamamsy, "Design of high-efficiency RF class-D power amplifier," *IEEE Trans. on power electronics*, vol. 9, pp. 297–308, May 1994.
- [5] M. P. Theodoridis and S. V. Mollov, "Robust MOSFET driver for RF, class-D inverters," *IEEE Transactions on industrial electronics*, vol. 55, pp. 731–740, Feb. 2008.
- [6] C. Grzesik, Z. Kaczmarczyk, and M. Kasprzak, "1 MHz sinusoidal gate driver for class DE inverter operating with variable load and frequency," in *Proc. IEEE 31st Annu. Power Electron. Spec. Conf.*, p. 817822, 2000.
- [7] H. Kobayashi, J. Hinrichs, and P. M. Asbeck, "Current mode class-D power amplifiers for high efficiency RF applications," *IEEE Trans. Microwave Theory and Techniques*, vol. 49, pp. 2480–2485, Dec. 2001.
- [8] T.-P. Hung, A. G. Metzger, P. J. Zampardi, M. Iwamoto, and P. M. Asbeck, "Design of high-efficiency current-mode class-D amplifiers for wireless handsets," *IEEE Transactions on Microwave Theory and Techniques*, vol. 53, pp. 144–151, Jan. 2005.
- [9] B. J. V. Donselaar, "Ferrites in HF applications- Transmissionline transformers." <http://sharon.esrac.ele.tue.nl/~on9cvd/E-Transmissielijn%20trafo's,%20voorbeelden.htm>.
- [10] G. Krausse, "Application note 1807: DRF series spice models." <http://www.microsemi.com/en/sites/default/files/datasheets/1807%20A.pdf>, Dec. 2009.
- [11] "LTspice." www.linear.com/designtools/software/.
- [12] G. Choi, "13.56 MHz, class D push-pull, 2 KW RF generator with microsemi DRF1300 power MOSFET hybrid," Tech. Rep. AN 1812, Microsemi, Sept. 2011.
- [13] "Material data sheets." <http://www.fair-rite.com/newfair/materials.htm>.