Machine Recognition of Sounds in Mixtures

Outline

- 1 Computational Auditory Scene Analysis**
- 2 Speech Recognition as Source Formation**
- 3 Sound Fragment Decoding**
- 4 Results & Conclusions**

Dan Ellis <dpwe@ee.columbia.edu>
LabROSA, Columbia University, New York

Jon Barker <j.barker@dcs.shef.ac.uk>
SPandH, Sheffield University, UK

1 Computational Auditory Scene Analysis (CASA)

- Human sound organization:
Auditory Scene Analysis

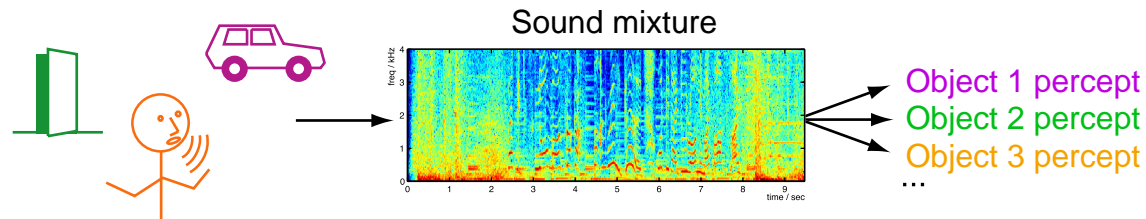

- composite sound signal → separate percepts
 - based on **ecological constraints**
 - acoustic cues → perceptual grouping
- **Computational ASA:**
Doing the same thing by computer
...?

What is the goal of CASA?

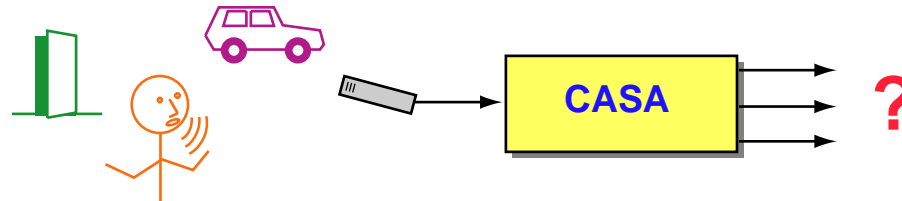

- **Separate signals?**
 - output is unmixed waveforms
 - underconstrained, very hard ...
 - too hard? not required?
- **Source classification?**
 - output is set of event-names
 - listeners do more than this...
- **Something in-between?**
Identify independent sources + characteristics
 - standard task, results?

Segregation vs. Inference

- **Source separation requires attribute separation**
 - sources are characterized by attributes (pitch, loudness, timbre + finer details)
 - need to identify & gather different attributes for different sources ...
- **Need representation that segregates attributes**
 - spectral decomposition
 - periodicity decomposition
- **Sometimes values can't be separated**
 - e.g. unvoiced speech
 - maybe **infer** factors from probabilistic model?
$$p(O, x, y) \rightarrow p(x, y | O)$$
 - or: just skip those values, **infer** from higher-level context

Outline

- 1 Computational Auditory Scene Analysis
- 2 **Speech Recognition as Source Formation**
 - Standard speech recognition
 - Handling mixtures
- 3 Sound Fragment Decoding
- 4 Results & Conclusions

2

Speech Recognition as Source Formation

- **Automatic Speech Recognition (ASR):**
the most advanced sound analysis
- **ASR extracts abstract information from sound**
 - (i.e. words)
 - even in mixtures (noisy backgrounds) .. a bit
- **ASR is not signal extraction:**
only certain signal information is recovered
 - .. just the bits we care about
- **Not CASA preprocessing for ASR:**
Instead, approach ASR as an example of CASA
 - words = description of source properties
 - uses strong prior constraints: signal models
 - but: must handle mixtures!

How ASR Represents Speech

- Markov model structure: states + transitions

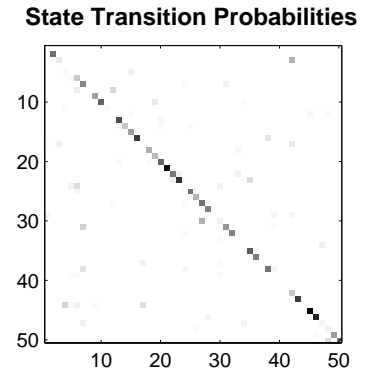
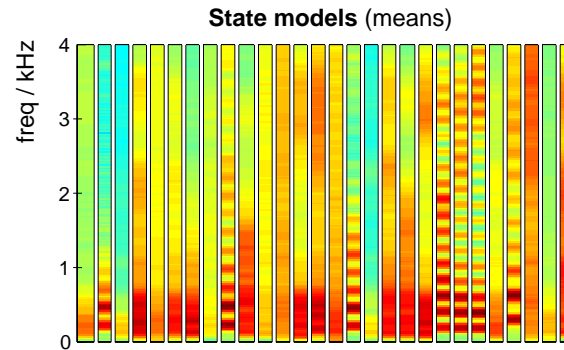
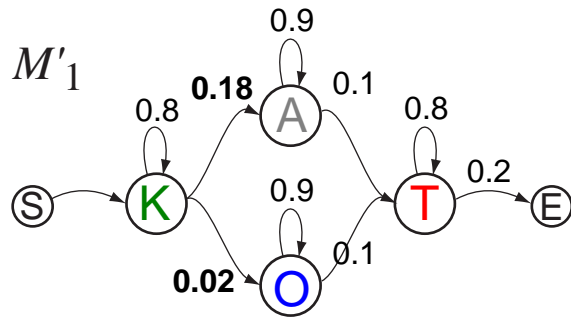

- Generative model
 - but not a good speech generator!

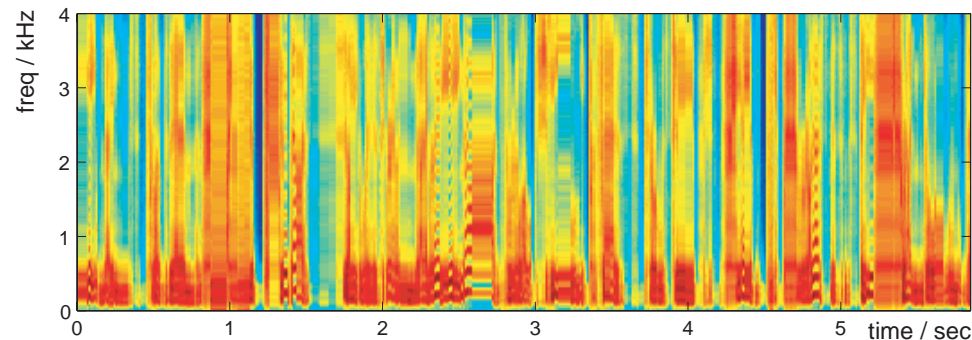

- only meant for **inference** of $p(X|M)$

Sequence Recognition

- **Statistical Pattern Recognition:**

$$M^* = \underset{\substack{M \\ \text{models}}}{\operatorname{argmax}} P(M|X) = \underset{M}{\operatorname{argmax}} \frac{P(X|M) \cdot P(M)}{P(X)}$$

← observations

- **Markov assumption decomposes into frames:**

$$P(X|M) = \prod_n p(x_n | m_n) p(m_n | m_{n-1})$$

- **Solve by searching over all possible state sequences $\{m_n\}$.. but with efficient pruning:**

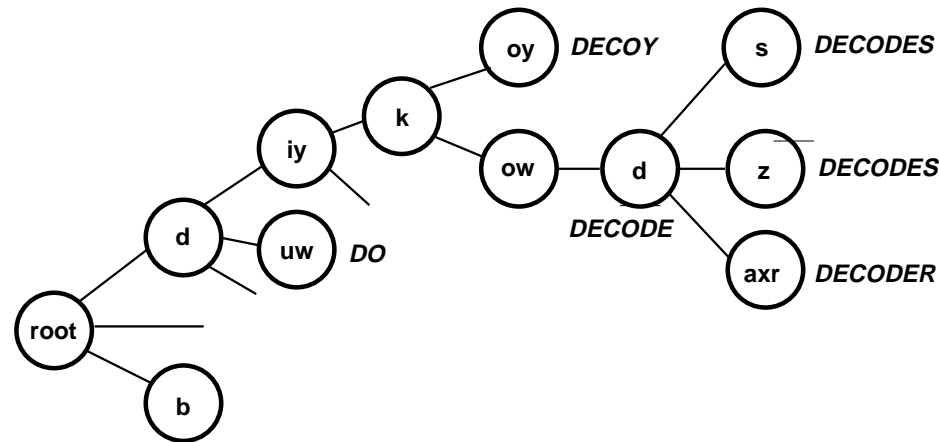

Approaches to sound mixture recognition

- **Separate signals, then recognize**
 - e.g. (traditional) CASA, ICA
 - nice, if you can do it
- **Recognize combined signal**
 - 'multicondition training'
 - combinatorics..
- **Recognize with parallel models**
 - full joint-state space?
 - divide signal into fragments,
then use missing-data recognition

Outline

- 1 Computational Auditory Scene Analysis
- 2 Speech Recognition as Source Formation
- 3 Sound Fragment Decoding**
 - Missing Data Recognition
 - Considering alternate segmentations
- 4 Results & Conclusions

3

Sound Fragment Decoding

- **Signal separation is too hard!**
Instead:
 - segregate features into **partially-observed** sources
 - then classify
- **Made possible by missing data recognition**
 - integrate over uncertainty in observations for true posterior distribution
- **Goal:**
Relate clean speech models $P(X|M)$ to speech-plus-noise mixture observations
 - .. and make it tractable

Missing Data Recognition

- **Speech models $p(\mathbf{x}|m)$ are multidimensional...**
 - i.e. means, variances for every freq. channel
 - need values for all dimensions to get $p(\bullet)$

- **But: can evaluate over a subset of dimensions x_k**

$$p(\mathbf{x}_k | m) = \int p(\mathbf{x}_k, \mathbf{x}_u | m) d\mathbf{x}_u$$

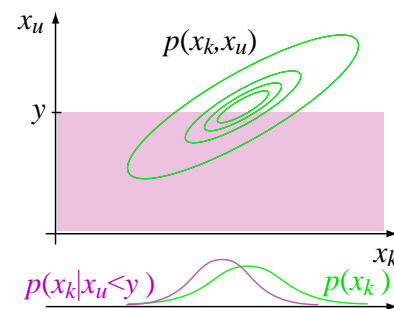

- **Hence, missing data recognition:**

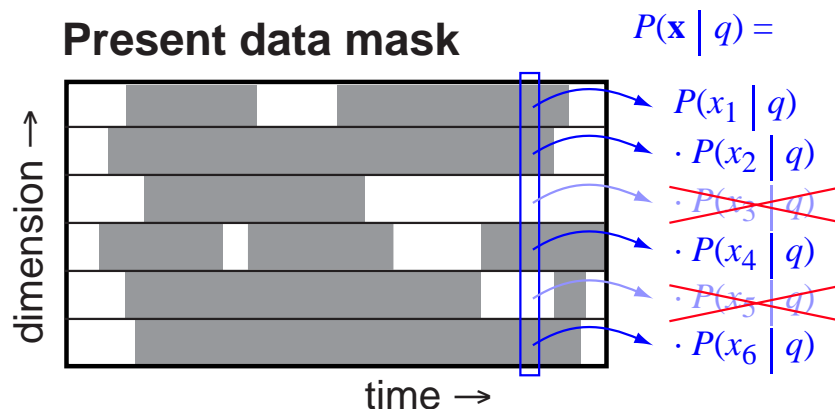

- hard part is finding the mask (segregation)

Missing Data Results

- Estimate static background noise level $N(f)$
- Cells with energy close to background are considered “missing”

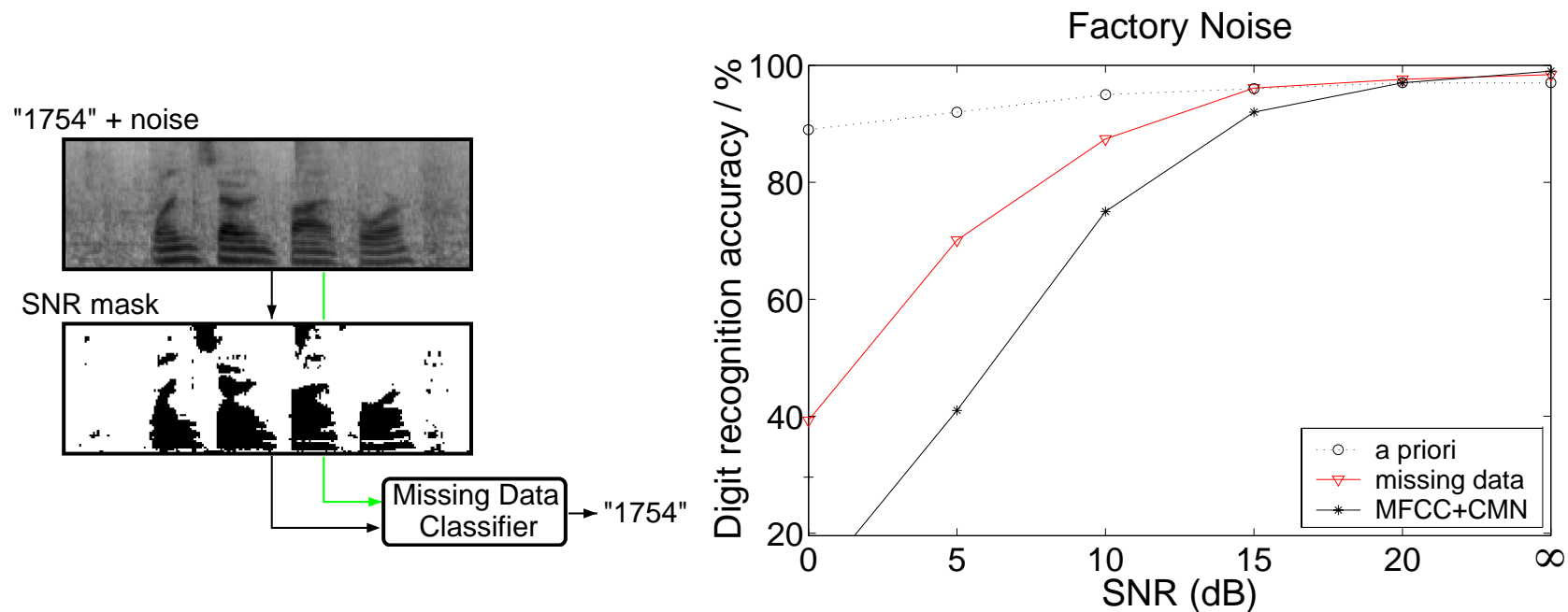

- must use spectral features!
- **But: nonstationary noise → spurious mask bits**
 - can we try **removing** parts of mask?

Comparing different segregations

- **Standard classification chooses between models M to match source features X**

$$M^* = \operatorname{argmax}_M P(M|X) = \operatorname{argmax}_M P(X|M) \cdot \frac{P(M)}{P(X)}$$

- **Mixtures: observed features Y , segregation S , all related by $P(X|Y, S)$**

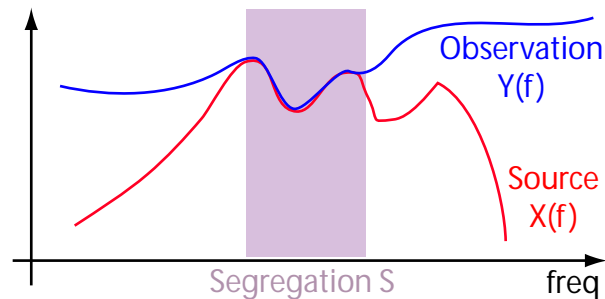

- **Joint classification of model and segregation:**

$$P(M, S|Y) = P(M) \int P(X|M) \cdot \frac{P(X|Y, S)}{P(X)} dX \cdot P(S|Y)$$

- $P(X)$ no longer constant

Calculating fragment matches

$$P(M, S|Y) = P(M) \int P(X|M) \cdot \frac{P(X|Y, S)}{P(X)} dX \cdot P(S|Y)$$

- $P(X|M)$ - the clean-signal feature model
- $P(X|Y,S)/P(X)$ - is X 'visible' given segregation?
- Integration collapses some bands...
- $P(S|Y)$ - segregation inferred from observation
 - just assume uniform, find S for most likely M
 - or: use extra information in Y to distinguish S 's...
- **Result:**
 - probabilistically-correct relation between clean-source models $P(X|M)$ and inferred, recognized **source** + segregation $P(M,S|Y)$

Using CASA features

- $P(S|Y)$ links acoustic information to segregation
 - is this segregation worth considering?
 - how likely is it?
- Opportunity for CASA-style information to contribute
 - periodicity/harmonicity:
these different frequency bands belong together
 - onset/continuity:
this time-frequency region must be whole

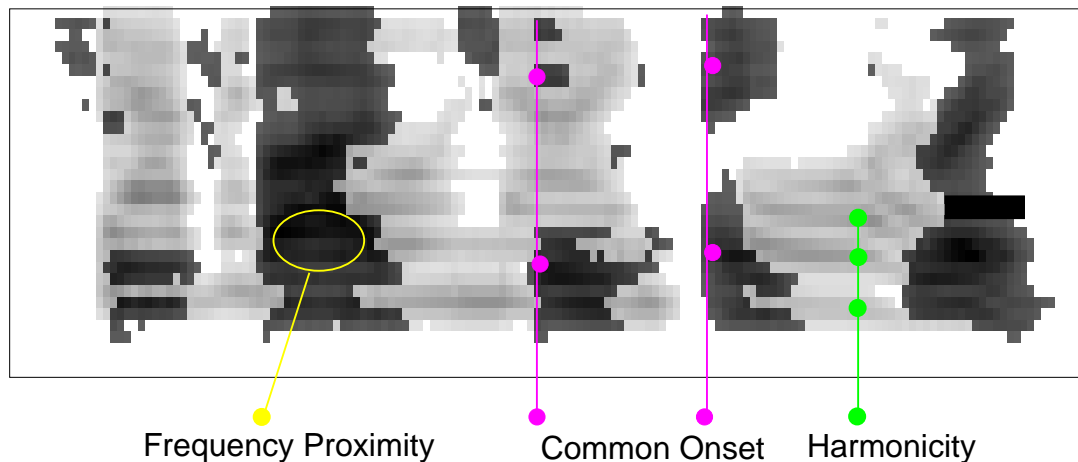

Fragment decoding

- Limiting S to whole fragments makes hypothesis search tractable:

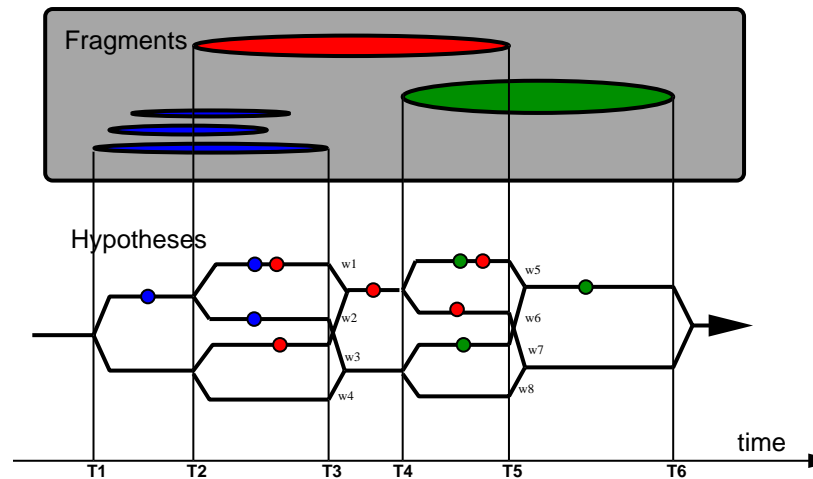

- choice of fragments reflects $P(S|Y) \cdot P(X|M)$
i.e. best combination of segregation
and match to speech models
- Merging hypotheses limits space demands
 - .. but erases specific history

Multi-Source Decoding

- Match multiple models at once?

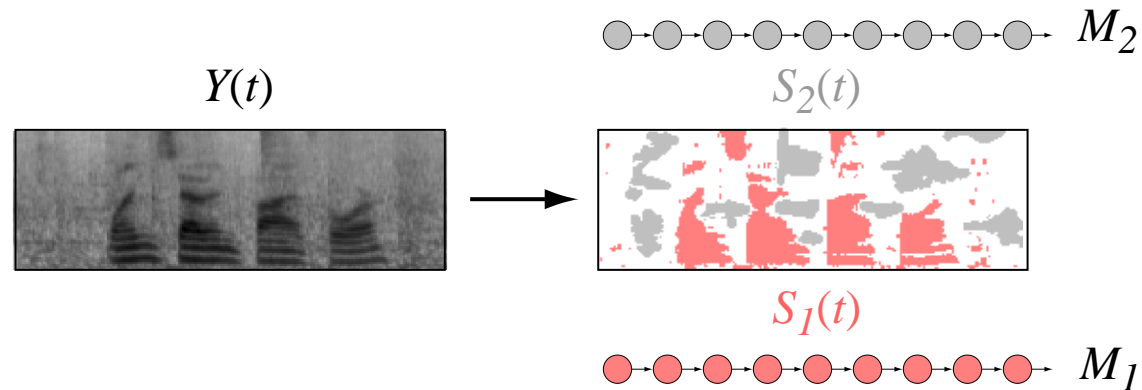

- disjoint subsets of cells for each source
- each model match $P(M_x|S_x, Y)$ is independent
- masks are mutually dependent: $P(S_1, S_2|Y)$

Outline

- 1 Computational Auditory Scene Analysis
- 2 Speech Recognition as Source Formation
- 3 Sound Fragment Decoding
- 4 **Results & Conclusions**
 - Speech recognition
 - Alarm detection

4 Speech fragment decoder results

- Simple $P(S|Y)$ model forces contiguous regions to stay together
 - big efficiency gain when searching S space

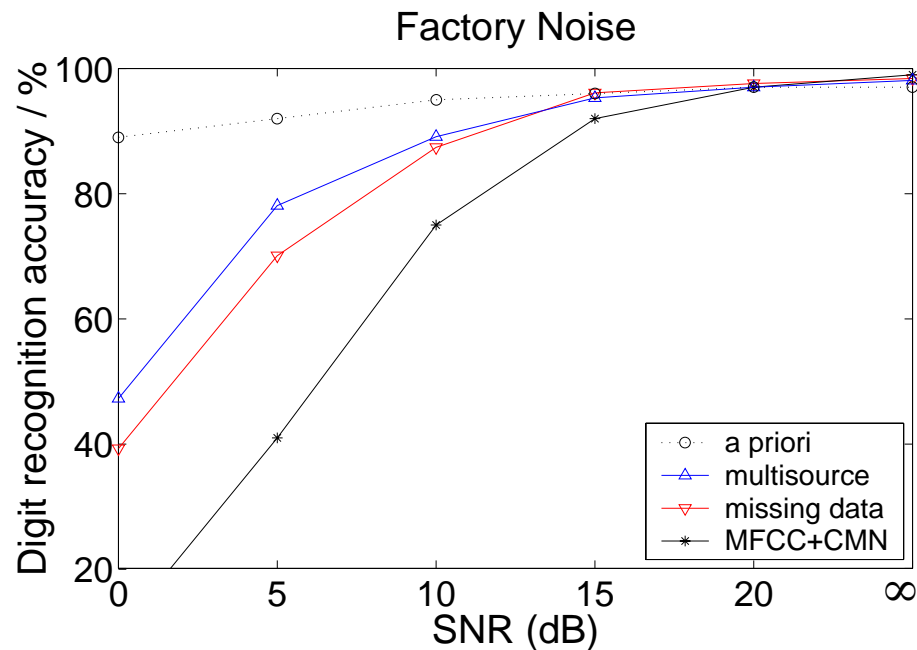
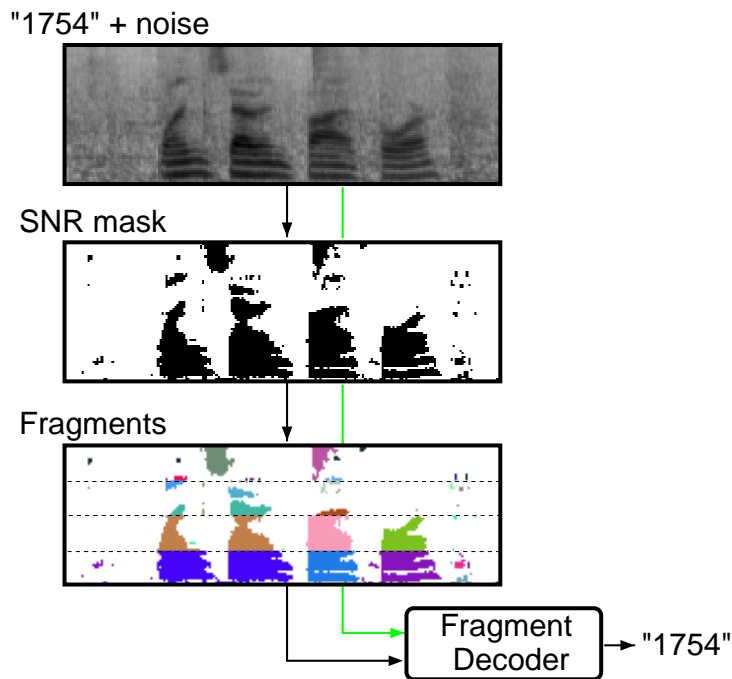

- **Clean-models-based recognition rivals trained-in-noise recognition**

Alarm sound detection

- Alarm sounds have particular **structure**
 - people 'know them when they hear them'
 - clear even at low SNRs

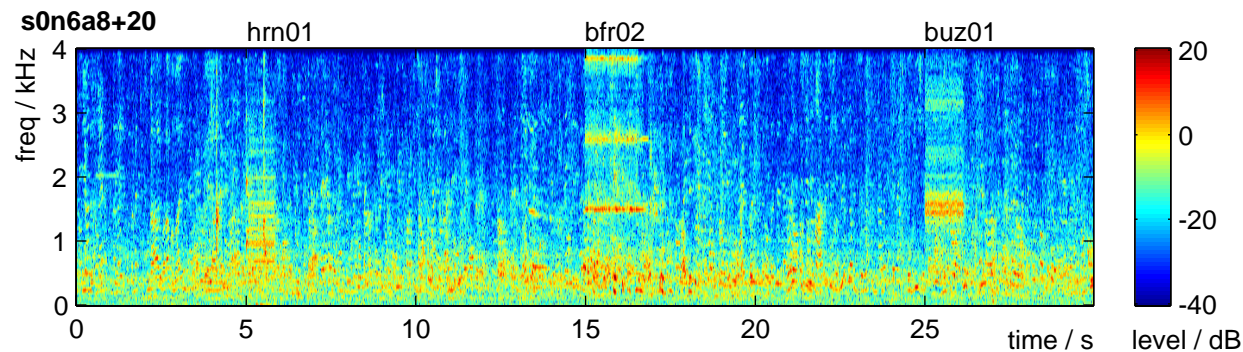

- Why investigate alarm sounds?
 - they're supposed to be **easy**
 - potential applications...
- Contrast two systems:
 - standard, **global features**, $P(X|M)$
 - sinusoidal model, **fragments**, $P(M,S|Y)$

Alarms: Results

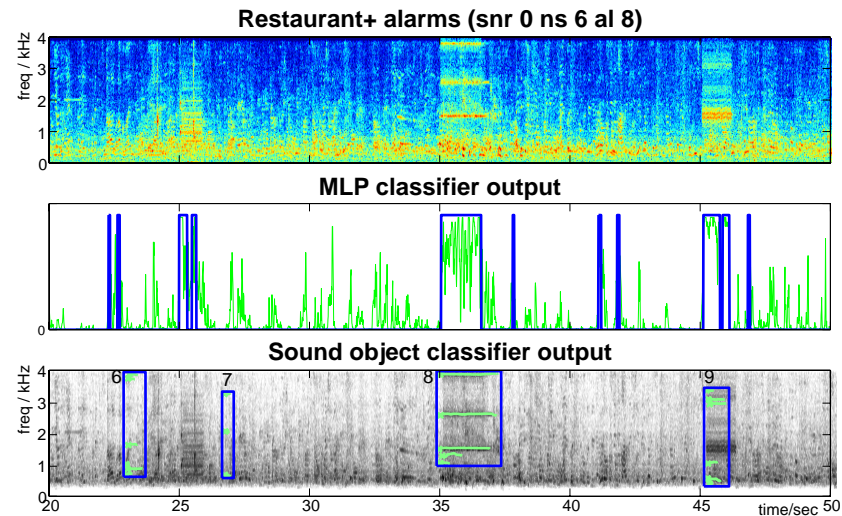

- Both systems commit many **insertions** at 0dB SNR, but in **different** circumstances:

Noise	Neural net system			Sinusoid model system		
	Del	Ins	Tot	Del	Ins	Tot
1 (amb)	7 / 25	2	36%	14 / 25	1	60%
2 (bab)	5 / 25	63	272%	15 / 25	2	68%
3 (spe)	2 / 25	68	280%	12 / 25	9	84%
4 (mus)	8 / 25	37	180%	9 / 25	135	576%
Overall	22 / 100	170	192%	50 / 100	147	197%

Summary & Conclusions

- **Scene Analysis**
 - necessary for useful hearing
- **Recognition**
 - a model domain for scene analysis
- **Fragment decoding**
 - recognition with partial observations
 - combines segmentation & model fitting
- **Future work**
 - models of sources other than speech
 - simultaneous 'perception' of multiple sources